

# SEFL - SEFLS

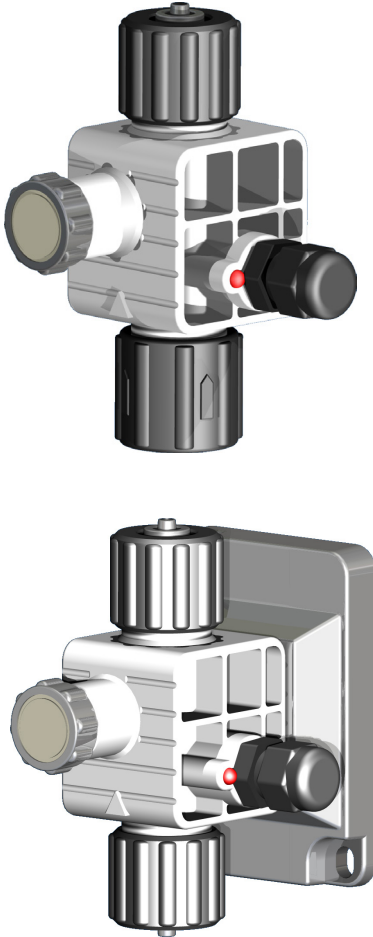

FLOW SENSORS

EN

OPERATING INSTRUCTIONS



**This operating instructions contains safety information that if ignored can endanger life or result in serious injury.**

The information contained in this manual may contain inaccuracies or typographical errors. The information contained in this publication is subject to change at any time without notice.

Version: R1-08-15

**THIS EQUIPMENT IS FOR DRINKING WATER TREATMENT.**

- ⚠ Use of this pump with radioactive chemicals is forbidden!**
- ⚠ When using this equipment with aggressive chemicals observe the regulations concerning the transport and storage of aggressive fluids!**
- ⚠ When installing always observe national regulations!**  
**Prima di ogni intervento di manutenzione:**
  - read chemical safety datasheet;
  - wear PPE (personal protective equipment) when handling hazardous or unknown chemicals;
  - discharge the liquid end before servicing the pump;
  - empty and rinse the liquid end before work on the equipment which has been used with hazardous or unknown chemicals.

This equipment complies to D.M. 7 February 2012 n.25 – D.M. 6 April 2004 n. 174 – Regulation EU 10/2011- Equipment intended to come into contact with food.

## INTRODUCTION

SEFL is a flow sensor device made for checking if the connected dosing pump is working properly by checking if a liquid is flowing through the pump's head. It has a control knob to regulate sensibility for every kind of pump.

- PVDF or PP body
- N.C. contact
- Adjustable sensitivity
- FKM B or EPDM O-ring
- Max 45°C
- Activity LED on board

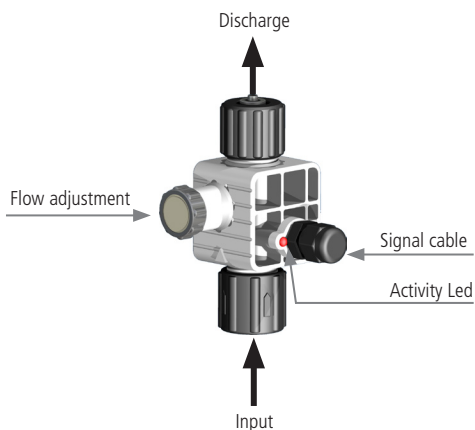

## MODELS

Models	Body and liquid ends	O-Ring	Fittings	Temp./ Pressure	Bracket and hose fixing kit	LPV* body
SEFL/D	PVDF	EPDM	1/2" - 3/8"	45°C/25 bar		
SEFLS/D	PVDF	EPDM	1/2" - 3/8"	45°C/25 bar	•	
SEFL/D/LPV	PVDF	EPDM	1/2" - 3/8"	45°C/25 bar		•
SEFL/V	PVDF	FKM B	1/2" - 3/8"	45°C/25 bar		
SEFLS/V	PVDF	FKM B	1/2" - 3/8"	45°C/25 bar	•	
SEFL/V/LPV	PVDF	FKM B	1/2" - 3/8"	45°C/25 bar		•

\* LPV body: for viscosity liquid application max 8.000 cps.

## INSTALLATION

1. Install SEFL connecting it to the pump head discharge connection. Take out the discharge connection tube nut and screw the SEFL connection onto the discharge.
2. Install the discharge hose on the discharge point of SEFL (top) locking it tight.
3. Carry out the electrical wiring connecting the SEFL to the MF pump or any other pump with sefl input. Working mode is a continuous ON/OFF contact.
4. Set flow adjustment so that activity led blinks every time the pump makes one stroke.

SEFL  
(fittings for installation on the pump)

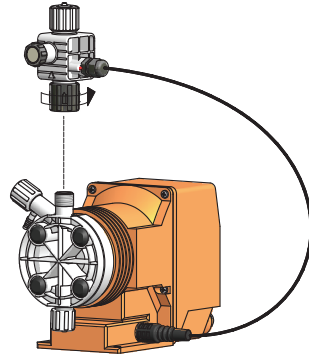

SEFL  
(bracket version. Hose fitting kit)

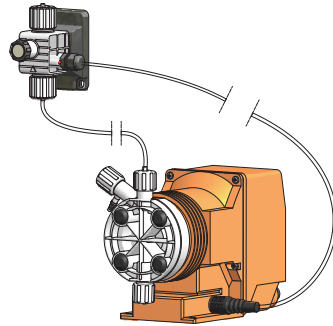

## INSTALLATION ON AMS AND CMS PUMP SERIES

### **⚠ ATTENTION**

On CMS and AMS pump series flow sensor SEFL must be installed at 50 cm minimum distance from the pump to avoid interference with the solenoid.

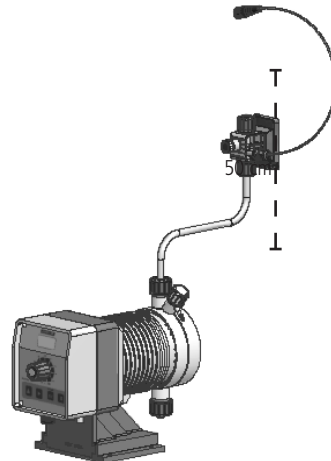

## DIMENSIONS

Dimensions: mm - [inches]

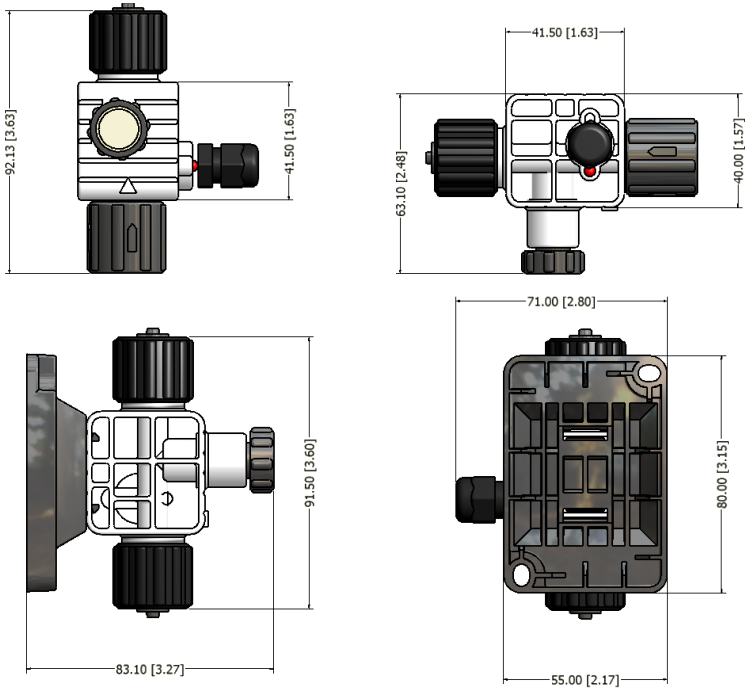

OPTION: PMMA BRACKET FOR KMS OR AMS MOUNTING.

