



REALTECH Controls
Technology Powered Solutions®

Instruction Manual

Triton TR80 Turbidity/Suspended Solids Sensor

with automated cleaning wiper

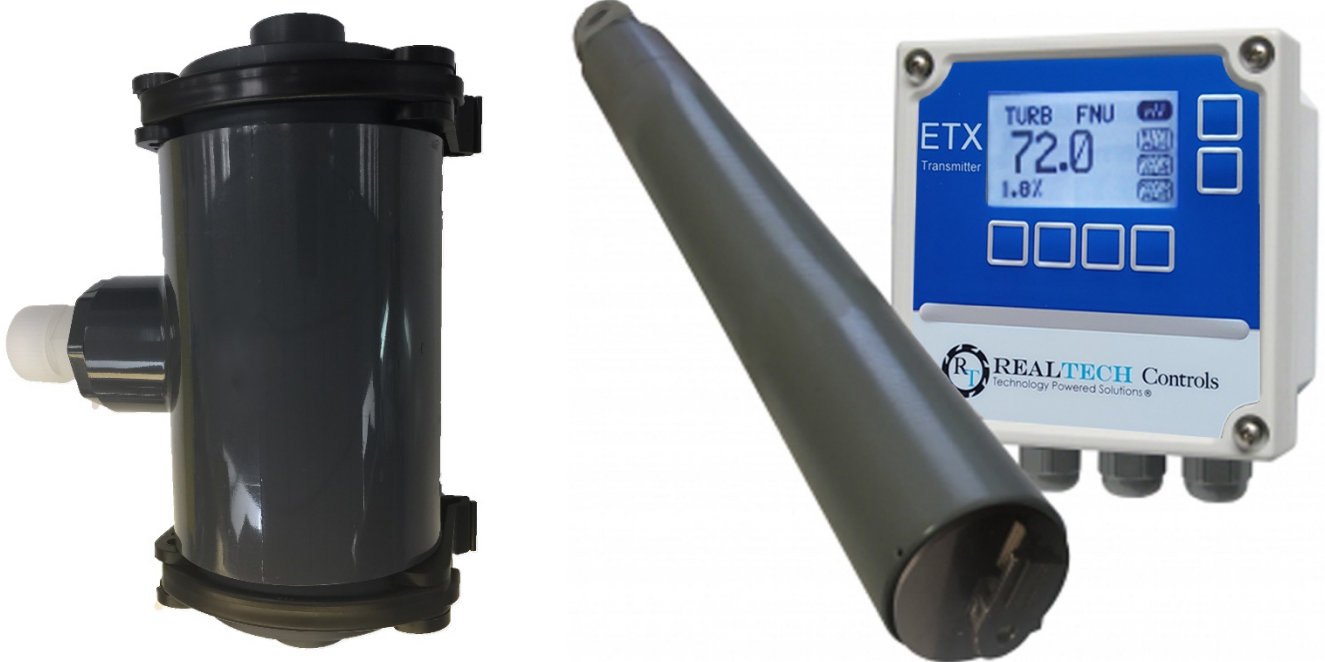

PREFACE

Purchasing products from RealTech Controls provides you with the finest liquid analytical instrumentation available. If this is your first purchase, please read the entire manual before installing and commissioning your new equipment.

If there are any questions concerning this equipment, please contact your local RealTech Controls representative, or the factory directly at:

RealTech Controls

Los Angeles, CA 91411 USA

Telephone: +1 (818) 606-0562



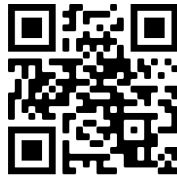

Website: <https://realtechcontrols.com>

E-mail: sales@realtechcontrols.com

QR Code:



SYMBOLS USED IN MANUAL

	This symbol is used to designate important information, warnings and cautions. Failure to follow this information could lead to harm to the instrument or user.
	No operator serviceable parts, service by authorized service personnel only.
	This symbol is used to designate a WARNING "Risk of Electrical Shock"
	Disconnect supply before servicing
	Equipment protected throughout by double insulation.

	Read the complete manual before installing or using the equipment.
---	--

Contents of this manual are believed to be correct at the time of printing and are subject to change without notice. RealTech Controls is not responsible for damage to the instrument, poor performance of the instrument or losses resulting from such, if the problems are caused by:

- Incorrect operation by the user.
- Use of the instrument in incorrect applications.
- Use of the instrument in an inappropriate environment or incorrect utility program (power supply).
- Repair or modification of the related instrument by anyone not authorized by RealTech Controls.
- There are no operator accessible parts. Service and maintenance to be done by authorized personnel only.
- If the equipment is used in a manner not specified by the manufacturer, the protection provided by the equipment may be impaired.

2017 RealTech Controls® All rights reserved. No part of this manual may be used or reproduced in any form or by any means, or stored in a database or retrieval system without prior written permission from RealTech Controls. Making copies of any part of this manual for any purpose other than personal use

TABLE OF CONTENTS

Preface.....	i
Symbols Used in Manual	ii
Terms and Conditions of Sale	1
Return Goods Policy	2
Unpacking the Instrument.....	3
1.0 Introduction.....	4
2.0 Installation.....	5
2.1 TR80 Installation.....	5
2.1.1 Standpipe Installation	5
2.1.2 Flow Cell Installation with De-Bubbler Option.....	6
2.1.3 Valve Retractable Installation	7
2.2 ETX Mounting	8
2.3 ETX Wiring	10
2.2.1 Wiring, Power	11
2.2.2 Wiring, Sensor	11
2.2.3 Wiring, 4-20 mA Outputs	12
2.2.4 Wiring, Contact Relay Outputs.....	12
2.2.5 Wiring, Serial Output MODBUS RTU	13
3.0 Operation	14
3.1 cONFIGURE automated wiper function	14
4.0 Calibration	15
4.1 AUTO Cal	16
4.2 Standardize.....	16
4.3 Manual Cal	17
5.0 Maintenance	18
6.0 Specifications.....	19
6.1 TR80 Turbidity/Suspended Solids Sensor.....	19
6.2 ETX Transmitter Specifications.....	20
7.0 Troubleshooting	21
8.0 Parts and Accessories (ETX)	22

8.1 Front Panel Control Board Exploded	22
8.2 Front Panel Control Board Exploded, with Relays.....	22
8.3 Transmitter Case, back with Cable Glands	23
8.4 Replacement Parts	24
8.5 Accessories	24

TERMS AND CONDITIONS OF SALE

1. **ACCEPTANCE.** If this writing differs in any way from the terms and conditions of Buyer's order or if this writing is construed as an acceptance or as a confirmation acting as an acceptance, then Seller's acceptance is **EXPRESSLY MADE CONDITIONAL ON BUYER'S ASSENT TO ANY TERMS AND CONDITIONS CONTAINED HEREIN THAT ARE DIFFERENT FROM OR ADDITIONAL TO THOSE CONTAINED IN BUYER'S WRITING.** Further, this writing shall be deemed notice of objection to such terms and conditions of Buyer. If this writing is construed as the offer, acceptance hereof is **EXPRESSLY LIMITED TO THE TERMS AND CONDITIONS CONTAINED HEREIN.** In any event, Buyer's acceptance of the goods shall manifest Buyer's assent to Seller's terms and conditions. No addition to or modification of these terms will be effective, unless set forth in writing and agreed to by Seller.
2. **WARRANTIES AND REMEDIES**
 - a. **Warranty.** Seller warrants to Buyer that it holds and will pass marketable title to the goods sold hereunder. Seller warrants to Buyer that the items and components manufactured by Seller will be free from defects in material and workmanship (subject, however, to tolerances and variances permitted by the trade hereunder) for a period one (1) year for non-consumable products. Consumable electrodes and sensors have a conditional warranty based shelf life and process conditions and is determined by Seller.
 - b. **Exclusion and Conditions.** Seller's obligations with respect to the express warranties and remedies contained herein are conditioned on the following: (i) Buyer's return of the non-conforming goods, if authorized by Seller; (ii) Buyer shall not assign its rights under these express warranties and any attempted assignment shall render such warranties, but not any disclaimers or limitations, void and the goods sold shall be sold **AS IS**; and (iii) all products shall be carefully inspected for damage by Buyer upon receipt, be properly calibrated for Buyer's particular use, and be used, repaired, and maintained by Buyer in accordance with the instructions set forth in Seller's product literature. Repair and maintenance by non-qualified personnel, product subjected to misuse or negligence, and/or damaged during shipment will invalidate the warranty, as will the use of non-approved consumables or spare parts. As with any other sophisticated product, it is essential, and a condition of Seller's warranty, that all personnel using the product be fully acquainted with its use, capabilities and limitations as set forth in the applicable product literature.
3. **DISCLAIMER OF IMPLIED WARRANTIES.** Seller gives no warranties except those expressly contained herein. Seller **disclaims** all other warranties implied by law usage of the trade, course of dealing or course of performance including, but not limited to, **the implied warranties of MERCHANTABILITY and fitness for a particular purpose.**
4. **LIMITATIONS OF LIABILITY.** The following limitations of Seller's liability are acknowledged by the parties to be fair and reasonable and shall apply to any act or omission hereunder, and to any breach of this contract of which these terms and conditions form a part:
 - a. **Disclaimer of Damage.** In no event shall Seller be liable for special, indirect, consequential or incidental damages whether arising under contract, warranty, tort, strict liability or any other theory of liability. Such damages include but are not limited to loss of profits, loss of use of goods, damage to property, and claims of third parties.
 - b. **Suitability.** Buyer acknowledges that it alone has determined the intended purpose and suitability of the goods sold hereunder. It is expressly agreed by the parties that any technical or other advice given by the Seller with respect to the use of the goods or services is given without charge and at Buyer's risk; therefore Seller assumes no obligation or liability for the advice given or results obtained.
 - c. **Notice and Time of Claims.**
 - i. Buyer agrees to check and inspect all products against shipping papers and for damage or shortage upon receipt of goods at destination.
 - ii. Every claim for shortage, damage in transit, or other cause visible upon inspection shall be deemed waived by the Buyer, or the Buyer's customer in the case of resale, unless delivered in writing to Seller by Buyer thirty (30) days from the tender of delivery of the goods to Buyer, provided, however, that claims for shortage must be made within seven (7) days of receipt.
 - iii. The parties expressly waive the statute of limitations and agree that any legal proceeding for any breach of this contract shall be waived unless filed within one (1) year after the accrual of the cause of action thereof.
5. **FORCE MAJEURE.** Seller shall not be liable for any delay in delivery, or failure to deliver, due to any cause beyond the Seller's control including but not limited to fires, floods, or other forces of the elements; strikes, or other labor disputes; accidents to machinery; acts of sabotage; riots; precedence or priorities granted at the request or for the benefit, directly or indirectly of the federal or any state government or any subdivision or agency thereof; delay in transportation or lack of transportation facilities; restrictions imposed by federal, state or other governmental legislation or rules or regulations thereof. If Seller, in its sole discretion, determines that Seller's performance hereunder would result in a loss to Seller's on this sale as computed under Seller's normal accounting procedures because of causes beyond Seller's control, then the Seller may terminate this agreement in whole or in part without liability for any delay in the delivery of, or failure to deliver, the goods sold hereunder
6. **TAXES AND OTHER CHARGES.** The Buyer will pay, or reimburse Seller if it pays, any and all taxes or tariffs or any other similar charges imposed upon this contract, the goods covered hereby or the delivery or use or resale thereof.
7. **FREIGHT CHARGES.** If the sale hereunder is other than F.O.B. Seller's facility, this acknowledgement is based upon the freight charges now in effect. In the event of an increase or decrease in applicable freight charges before the goods are shipped, such charge in freight will be for the Buyer's account.
8. **PRICES AND DELIVERY.** Prices quoted herein are F.O.B. shipping point. Deliveries specified are only our best estimate and are subject to change. This quotation is based upon freight charges now in effect. Buyer will be invoiced at the freight charge prevailing at the date of shipment. Prices are firm for orders meeting Seller's normal shipping schedules. If shipments are held or postponed for any reason other than Seller's fault, and a price increase becomes effective during the period of such hold or postponement, the increase will apply to all shipments that are held or postponed thirty (30) days or more from the effective date of the increase.
9. **PAYMENTS.** If in the judgment of Seller the financial condition of Buyer at any time prior to shipment does not justify the terms of payment specified, Seller may cancel the order, withhold shipment, and/or require full or partial payment in advance. If payment is not made when due, Seller may suspend all future delivery or other performance with respect to Buyer without liability or penalty and, in addition to all other sums payable hereunder, Buyer shall pay to Seller (i) the reasonable costs and expenses incurred by Seller in connection with all actions taken to enforce collection or to preserve and protect Seller's rights hereunder, whether by legal proceedings or otherwise, including without limitation reasonable attorneys' fees, court costs and other expenses and (ii) interest on all amounts unpaid after 30 days charged at the monthly rate of 1-1/2% or the highest rate permitted by law, whichever is lower.
10. **CANCELLATION OR ALTERATION.** Buyer may not alter or cancel any order without Seller's written consent. For any order altered or cancelled with Seller's consent, Buyer must pay for all expenses and labor incurred up to the time of Seller's consent, plus a reasonable percentage for profit. Any order delayed or deferred by Buyer will be subject to price escalation for increased costs of production, and any other expenses caused by the delay. Material on such orders will be stored at Buyer's risk. Seller reserves the right to invoice Buyer and require payment before shipment of any delayed or deferred order.
11. **TITLE AND RISK OF LOSS.** Title and risk of loss shall pass to buyer at Anaheim, California, unless otherwise specified in the contract. If delivery is made by common carrier, risk of loss shall pass upon delivery to the carrier. Claims for loss or damage in transit must be made by Buyer to the carrier. Seller accepts no responsibility for loss or damage to product in transit.
12. **PATENT OR TRADEMARK INFRINGEMENT.** If the goods sold hereunder are to be prepared for manufacture according to Buyers specification, Buyer shall indemnify Seller against any claim or liability for patent, trademark, service mark or trade name infringement on account of preparation, manufacture and/or sale.
13. **NON-WAIVER.** If Government Contract Regulations require the addition, deletion, or modification of these terms and conditions upon prior notification to Seller and Seller's written acceptance thereof, such changes shall become a part of these terms and conditions. Seller shall not be bound by any Government Contract Regulations applicable to Buyer's contracts with the U.S. Government unless Buyer has expressly acknowledged, on the face of this document, the applicability of such Regulations to the transaction between Buyer and Seller contemplated herein. Absent such acknowledgement, Seller is making the assumption in issuing this document that no such Regulations apply.
14. **JURISDICTION.** All such disputes shall be resolved in a court of competent jurisdiction in Orange County, California. Buyer hereby consents to the jurisdiction of the State and Federal Courts sitting in Orange County. Notwithstanding the above, should either party contest the jurisdiction of such courts, the other party may institute its suit in any court of competent jurisdiction.
15. **APPLICABLE LAW.** All questions arising hereunder or in connection with the quotations or any order submitted in connection therewith and/or the performance of the parties hereunder shall be interpreted and resolved in accordance with the laws of the state of California without regard to its conflict of law provisions and excluding the United Nations Convention on the International Sale of Goods.

RETURN GOODS POLICY

All requests for returned goods must be initiated through our Customer Service Department. Please call our phone number (818) 606-0562 with the specifics of your request. The following conditions must be satisfied for consideration of applicable credit for the return of products purchased from RealTech Controls:

- 1) The item is unused and in the original package.
- 2) The item was shipped directly from RealTech Controls.
- 3) The item has not been damaged in shipment to RealTech Controls.
- 4) Items containing date-sensitive parts such as electrodes, must be returned within 1 month of the invoiced date.
- 5) Items without date-sensitive parts must be returned within 3 months of the invoiced date.

A Return Merchandize Authorization Number must be obtained from Customer Service and be provided on all paperwork and packaging. To obtain a Return Merchandize Authorization Number, please provide the reason for return, the date of purchase, your original purchase order number, and either our order number or our invoice number. The issuance of a Return Merchandize Authorization Number is a verbal approval for return only and does not guarantee credit or allowance. Returned goods must be received within 30 days of the issuance date of the Return Merchandize Authorization Number or it will become null and void.

Necessary physical and mechanical inspection is completed upon receipt of the item. Applicable credit or equivalent allowance is determined after inspection of the returned item. If all of the above conditions are met, and the item has been approved to return to our stock, a restocking charge of 25% of the purchase price is deducted from the applicable credit.

UNPACKING THE INSTRUMENT

Your RealTech Controls instrument has been carefully packaged to protect it from damage during shipment and dry storage. Upon receipt, please follow the procedure outlined below.

1. Before unpacking, inspect the condition of the shipping container to verify proper handling by the carrier. If damage is noted, save the shipping container as proof of mishandling for the carrier.
2. Check the contents of the shipping container with the items and quantities shown on the packing list. Immediately report any discrepancies to RealTech Controls.
3. Save the original packing material until you are satisfied with the contents. In the event the product(s) must be returned to RealTech Controls, the packing material will allow you to properly ship it to RealTech Controls.
4. Familiarize yourself with the instrument before installation, and follow proper installation and wiring procedures.



WARNING Electrical installation must be in accordance with the National Electrical Code (ANSI/NFPA-70), Canadian Electrical Code and/or any other applicable national or local codes.

INSTALLATION AND WIRING

Failure to follow the proper instructions may cause damage to this instrument and warranty invalidation. Use only qualified personnel to install, operate and maintain the product.

The Model TR80 Sensor should only be used with equipment that meets the relevant IEC, American or Canadian standards. RealTech Controls accepts no responsibility for the misuse of this unit.

1.0 INTRODUCTION

The Triton TR80 is a nephelometric turbidity sensor designed for use in water and wastewater. Turbidity, the cloudiness or haziness of a water sample, is caused by particles suspended in the water, typically clay and silt. Since bacteria and viruses can be attached to these particles, turbidity has become a critical indicator of the overall water quality. The Triton TR80 uses an optical method for determining the turbidity, a light beam is directed into the sample where it is scattered by suspended particles in the water. The amount of scattering depends on the amount of material in the water, the wavelength of light, and the size and composition of the suspended particles. The Triton TR80 uses a near infrared LED light source and the 90° scattered light method in accordance with ISO 7027 / EN 27027 to assure accurate turbidity values under standardized and comparable conditions.

The TR80 incorporates an automated mechanical wiper design which can be programmed for frequency and duration. This can be controlled by the ETX Transmitter, LQ800 Multi-Channel Controller or manually activated by a remote switch.

The TR80 response depends on the size, shape and composition of the suspended particles. For this reason, mg/L, ppm and % Solids measurements must be calibrated with suspended solids from the waters to be monitored. Turbidity measurements (NTU, FNU) can be calibrated with calibration standards such as Formazin, StabCal, or SDVB beads.



Immersion Holder

Flow Through Assembly

De-bubbler Assembly

The TR80 sensors are available in (4) different ranges. The sensors are 10 inch by 1.315 inch diameter with a 3/4 MNPT thread on the back of the sensor. This allows the sensor to be inserted into a 1" pipe coupling or to be mounted by the back of the sensor utilizing the 3/3 MNPT threads for standpipe installations. The body of the sensor is either CPVC or polypropylene material and ranges include <30 NTU, 0 to 1000 NTU, 0-4000 NTU, 0-5000 mg/L, 5000-10,000 mg/L (mud/clay) and 50,000-100,000 mg/L (sand).

The Triton TR80 sensors are designed to work with the ETX transmitter. The ETX is a single or dual channel transmitter with one or two 4-20mA outputs with MODBUS RTU and optional (3) Alarm Relays or HART 7 communication. The ETX Transmitter allows the suspended solids measurement to be combined with any of its other standard measurements using the S80 pH, S80 ORP, S80 plon, S80 Conductivity or S80 Dissolved Oxygen or DO82 sensors.

The Triton TR80 uses an optical method for determining the turbidity. A light beam is directed into the sample where it is scattered by suspended particles in the water. The amount of scattering depends on the amount of material in the water, the wavelength of light used, and the size and composition of the suspended particles. Designed for use in environmental water, the Triton TR80 is suitable for most aqueous applications. It is not suitable for use in organic solvents or in solutions with an extreme pH value, only use when the pH is between 2-12 pH. The temperature range for the sensor is 5° to 50°C. Turbidity, the cloudiness or haziness of a water sample, is caused by particles suspended in the water, typically clay and silt. Since bacteria and viruses can be attached to these particles, turbidity has become a critical indicator of the overall water quality.

2.0 INSTALLATION

2.1 TR80 INSTALLATION

TR80 Installation can be accomplished with a 1" stand pipe for immersion service, flow cell for an in line flow through application or flow cell with built-in De-Bubbler for Micro air bubble applications, or a valve retractable configuration. Refer to the Following drawing configurations. Applications of < 30 NTU should use a Flow cell or the De-Bubbler assembly for best accuracy, and must be calibrated in the Flow Cell or De-Bubbler Assembly. The standard cable is a water-proof 6 conductor cable. It is available with 10", 20", or 30" (9.1 meters) lengths.

2.1.1 STANDPIPE INSTALLATION

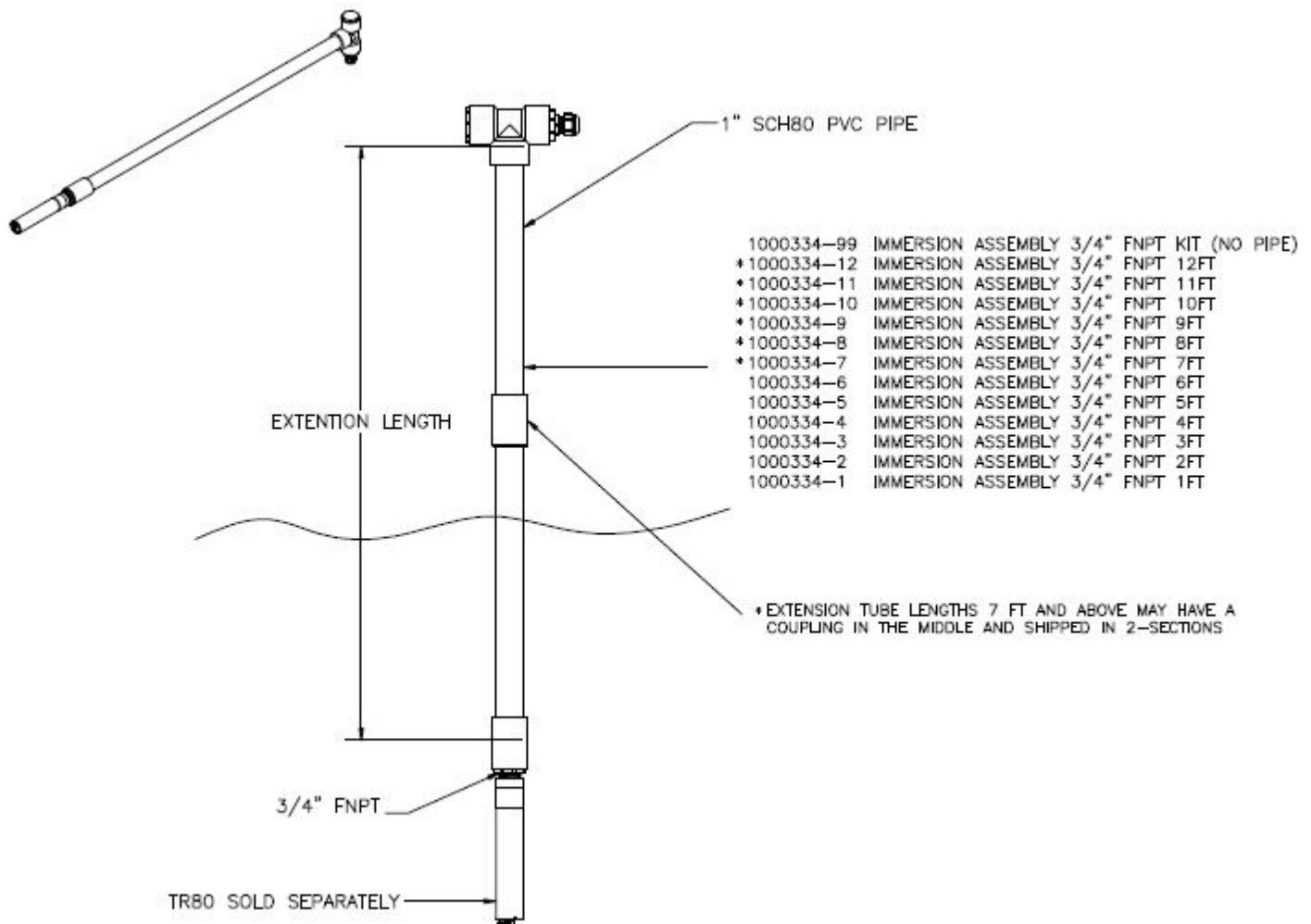

Standpipe Installation

2.1.2 FLOW CELL INSTALLATION WITH DE-BUBBLER OPTION

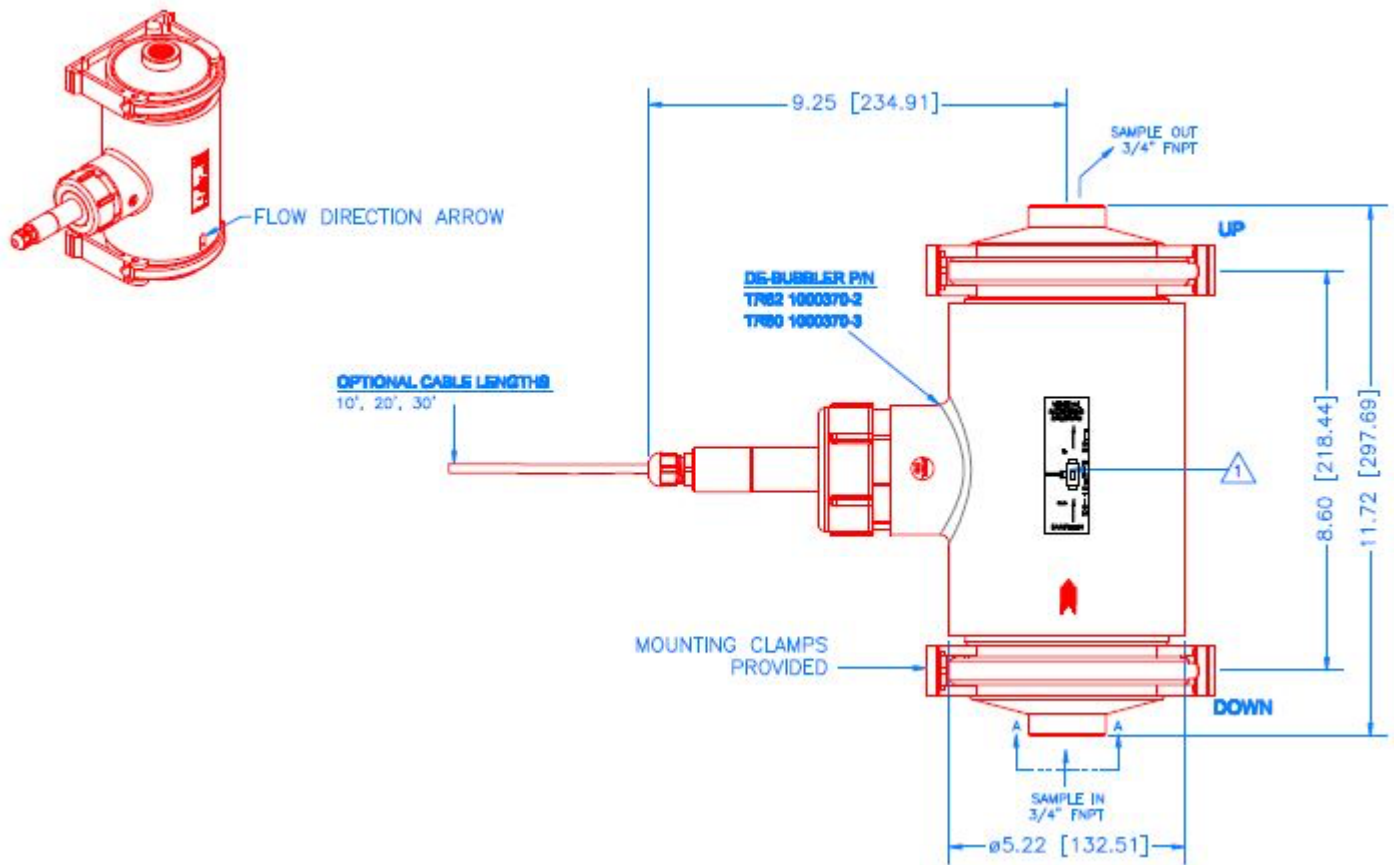

Flow Cell Installation

2.1.3 VALVE RETRACTABLE INSTALLATION

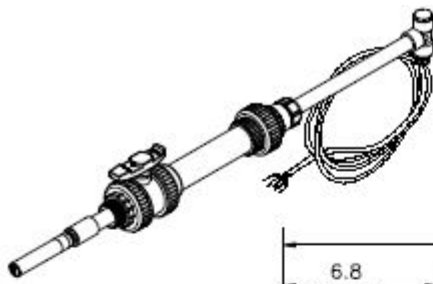

VALVE SHOWN WITH OPTIONAL TR80 SENSOR

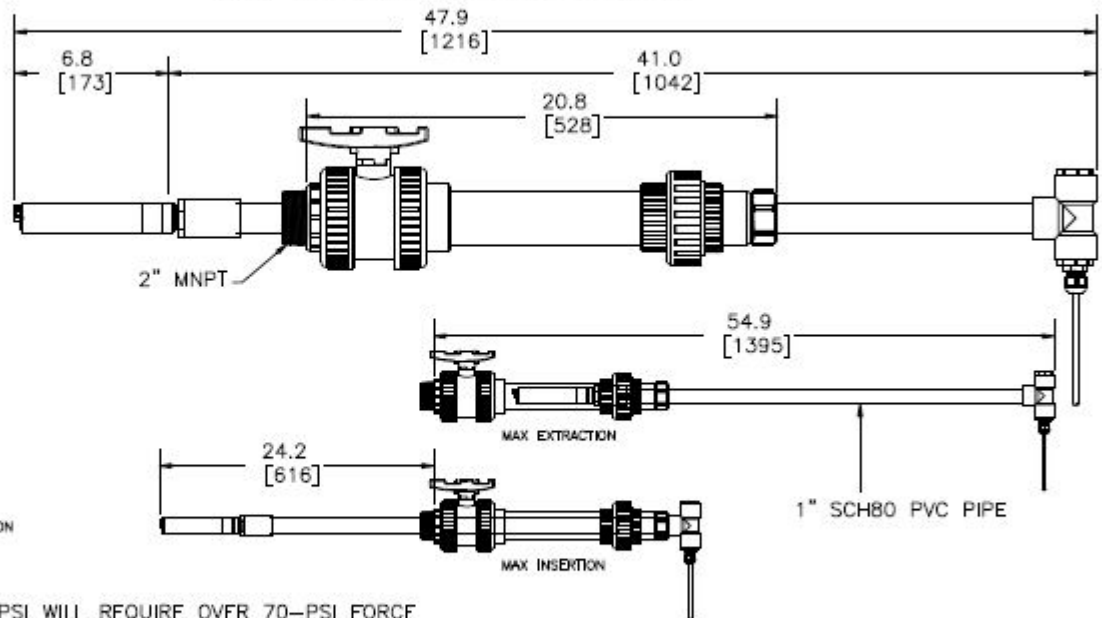

RATING:

40 PSI MAX FOR RETRACTION
100 PSI MAX FOR STATIC INSTALLATION

WARNING:

RETRACTION UNDER 40-PSI WILL REQUIRE OVER 70-PSI FORCE TO HOLD SENSOR IN PLACE. FOR SAFETY REASONS, IT IS BEST TO DEPRESSURIZE BEFORE RETRACTION. USE EXTREME CAUTION WHEN RETRACTING SENSOR.

2. SENSOR SOLD SEPARATELY

1. REF ASSY #: 1000251-3 VALVE RETRACTABLE ASSY DOBO/TR80 WITH 3/4" NPT THREAD

Valve Retractable Installation

2.2 ETX MOUNTING

Mount the ETX in a location where there is easy access to the analyzer and sensors. Install the system in an area where vibrations, electromagnetic and radio frequency interference are minimized or absent. Do not mount in direct sunlight or areas of extreme heat (temperature > 120°F). The IP65 ETX is suitable for outdoor use but is best to mount it with a protective cover or sunshield to prevent discoloring over the years.

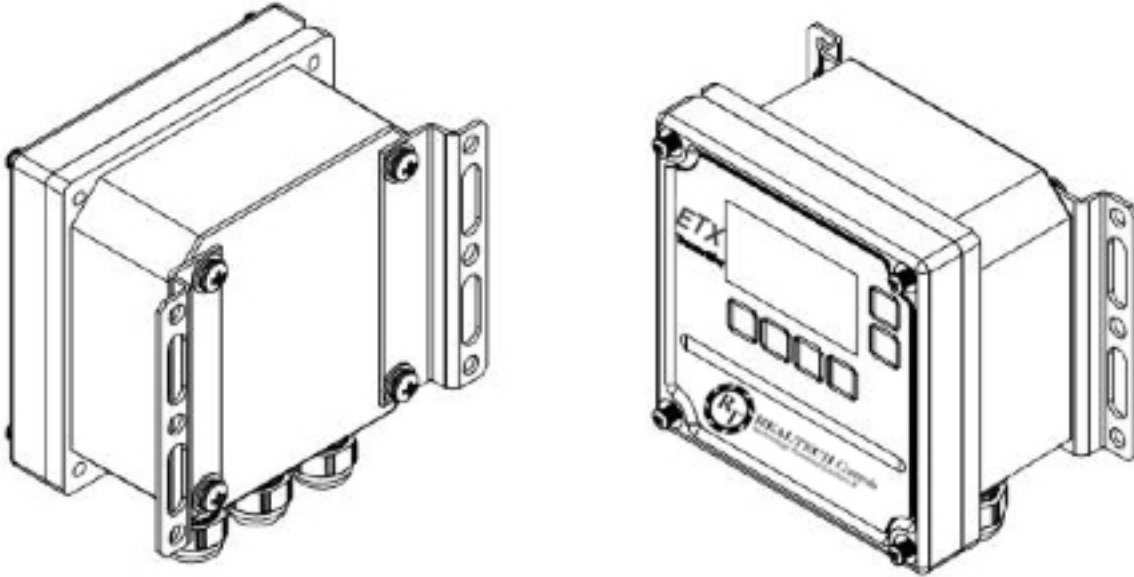

Universal Mounting Brackets

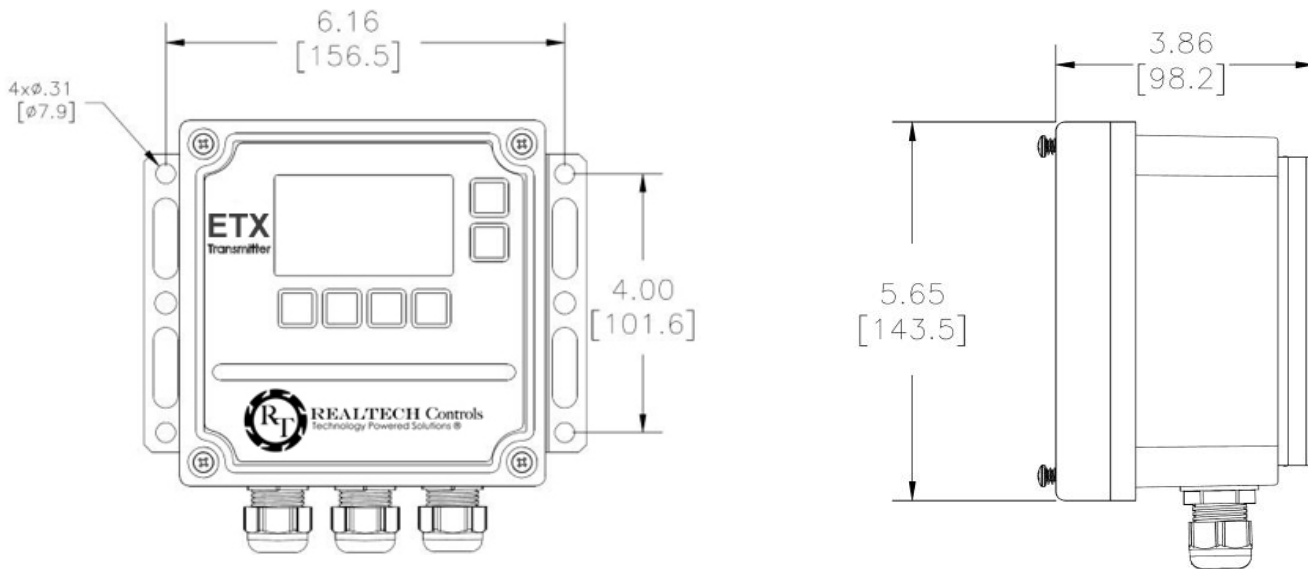

Rail Mounting

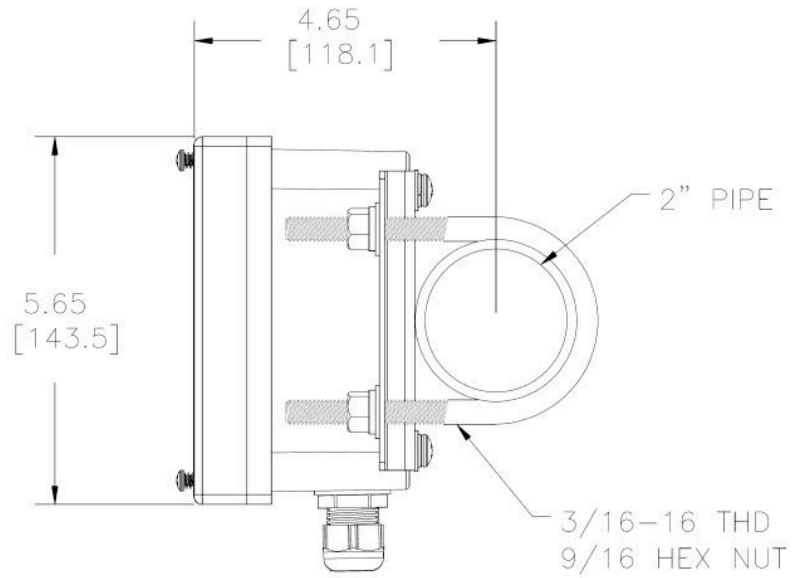
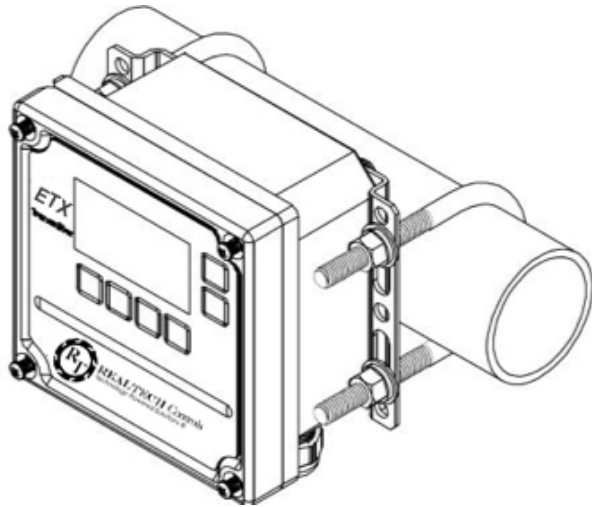

Panel Mounting

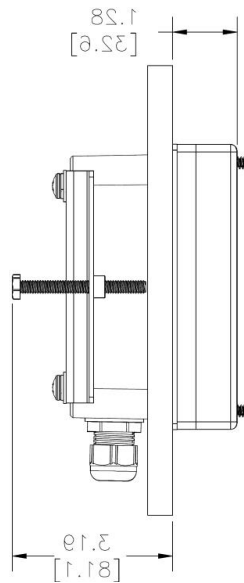
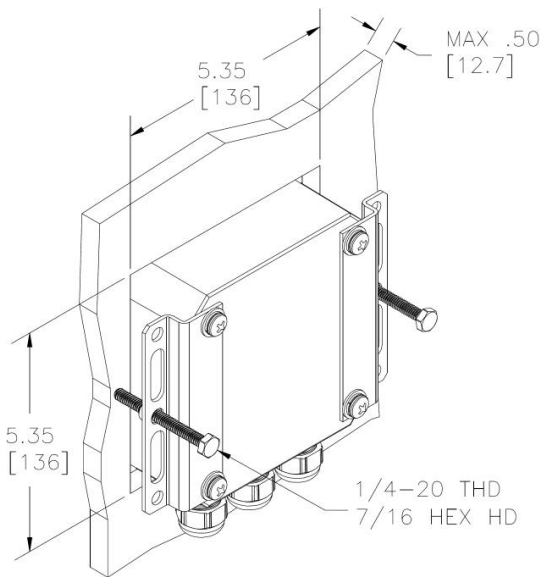

Cut Out: 5.35" x 5.35" (13.6cm x 13.6cm)

2.3 ETX WIRING

Electrical wiring should only be conducted by qualified personnel. See the ETX wiring diagram in figure 2.2X

(Note: Loop Powered configuration is not available for turbidity sensors, only S80 sensors)

Figure 2.2.1 Loop Powered Transmitter

Note: Loop powered 2-wire configuration not available for turbidity sensor

Figure 2.2.2 ETX Transmitter, 4-wire, 24VDC or 110/220 VAC, Sensor, MODBUS, wiper control terminal block wiring

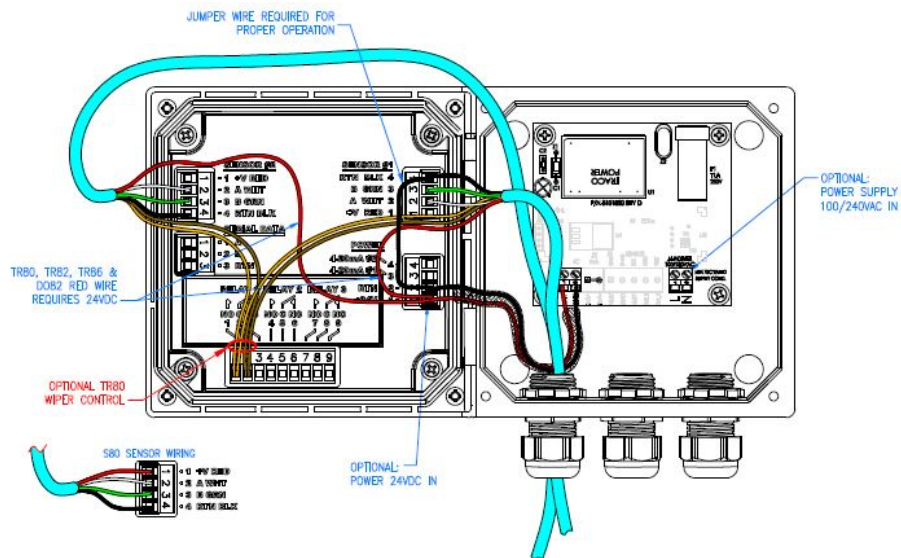
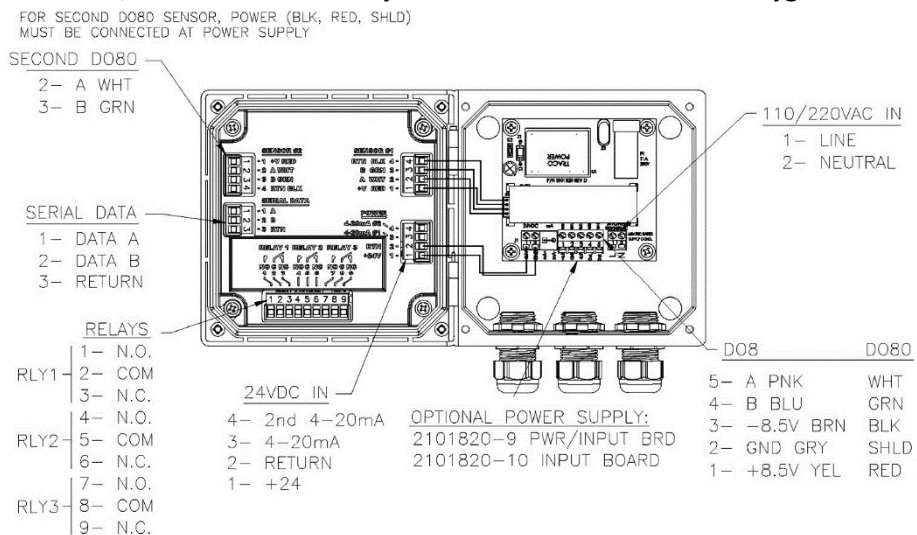





Figure 2.2.3 4-Wire Transmitter, Model TR80 turbidity and Model DO82 Dissolved Oxygen Sensors



	Warning: RISK OF ELECTRICAL SHOCK
	Disconnect Power before opening instrument.
	WARNING Electrical installation must be in accordance with the National Electrical Code (ANSI/NFPA-70), Canadian Electrical Code, and/or any other applicable national or local codes.

2.2.1 WIRING, POWER

RealTech Controls recommends using thermoplastic, outdoor sunlight resistant jacketed cable wet location rated, and ½” flexible conduit. The power should be hard wired with a switch or breaker to disconnect the analyzer from the main power supply. Install the switch or breaker near the analyzer and label it as the Power switch for the analyzer.

Loop Powered (2 wire configuration)

Not available for turbidity sensors, only available with S80 sensors.

24VDC (4 wire configuration)

Attach the 24VDC power cable to terminals #1 and #2 as shown in Figure 2.2.2 and on the diagram inside of the ETX cover. Attach the 4-20 mA1 cable to terminals #3 (out) and #2 (return) single channel unit and attach the 4-20 mA2 cable to terminals #4 (out) and #2 (return) for a two channel instrument. Feed the cables through the gland fitting on the right side of the ETX. Tighten the cable gland to provide a good seal to the cable. The instrumentation can be powered up at this point with no harm to the analyzer but it is best to wait until the sensor is installed.

110/220 VAC (4 wire configuration)

Attach power cable as shown in Figure 2.2.2 or as on the diagram inside of the ETX cover. Feed the cable through the gland fitting on the right hand side of the ETX. Tighten the cable gland to provide a good seal to the cable. The instrument can be powered up at this point with no harm to the analyzer but it is best to wait until the sensor is installed.

2.2.2 WIRING, SENSOR

Attach the sensor wires as described on the diagram inside the ETX cover. Feed the sensor cable through the gland fitting on the left hand side of the ETX. Do not use the same gland fitting for the AC power or Alarm/Relays. The green terminal strip connectors are detachable from the circuit boards. Remove the connector by pulling straight back from the circuit board.

NOTE: The TR82 Sensor requires +24 VDC (this is different than a S80 sensor). The sensor red wire should connect to the +24 VDC power terminal/connector only. Refer to wiring diagram and wiring instructions as follows:

Wire the TR80 sensor as follows: for 1 channel transmitters wire to sensor #1 terminal block, for 2 channel transmitters wire to sensor #1 and sensor #2 terminal block. Connect the white wire to the sensor terminal position 2 (A WHT), connect the green wire to terminal position 3 (B GRN), connect the black wire to terminal position 4 (RTN BLK), connect the red wire (longer) directly to the power terminal block +24V position 4 and this position is shared with the +24VDC input power wire (For AC powered transmitters, DO NOT connect AC power to this position) (DO NOT connect to the +V on sensor terminal this should remain unconnected). Next, connect a jumper wire from Sensor #1 terminal block position 4 (RTN BLK), this is shared position with the black sensor wire, and the other end of the jumper wire to the power terminal

position 2 and this position is also shared with the +24VDC input power return (For AC powered transmitters, DO NOT connect AC power to this position)

Lastly, for the automated wiper control, the wires are Orange and Brown. The wiper is activated anytime these two wires are momentarily connected together. The ETX Transmitter can control the frequency and duration of the wiper activation. For this function connect the orange (ORG) wire to the relay terminal block, position 1 (RLY1 NO) and the brown wire (BRN) to position 2 (RLY1 COM). For 2 Channel Transmitters configured with two TR80 sensors, both set of these wires (Orange and Brown) can be connected to the same terminal positions or can be activated separately but using an additional Relay 2 (NO and C).

Also, the wiper can be manually activated by connecting these same to wires to a momentary Normally Open switch. Each time the switch is activated, the wiper will complete one wiping revolution. If configured this way, it should be noted that during the wiper action, the sensor measurement will change during the wiper motion and then return to normal readings. One can place the transmitter in hold mode, keeping the current reading, activate the wiper, then return the transmitter to normal operation. If using the automated wiper function, this hold feature is automatically programmed into the operations.

Refer to section 3.1 for Configuring Automated Wiper Function.

2.2.3 WIRING, 4-20 MA OUTPUTS

24 VDC or 110/220 VAC powered instruments:

For instruments powered with 24VDC or the internet power supply, Model ETX-XX-1X-XX (24VDC) and ETX-XX-2X-XX (110/220 VAC), connect the 4-20 mA cable(s) to terminals #3 (out) for channel 1 and #2 (return) and to terminals #4 (out) for channel 2 and #2 (return).

Transmitters with HART® Communication can be wired as shown below. See HART® Communication menu in Appendix 9.2:

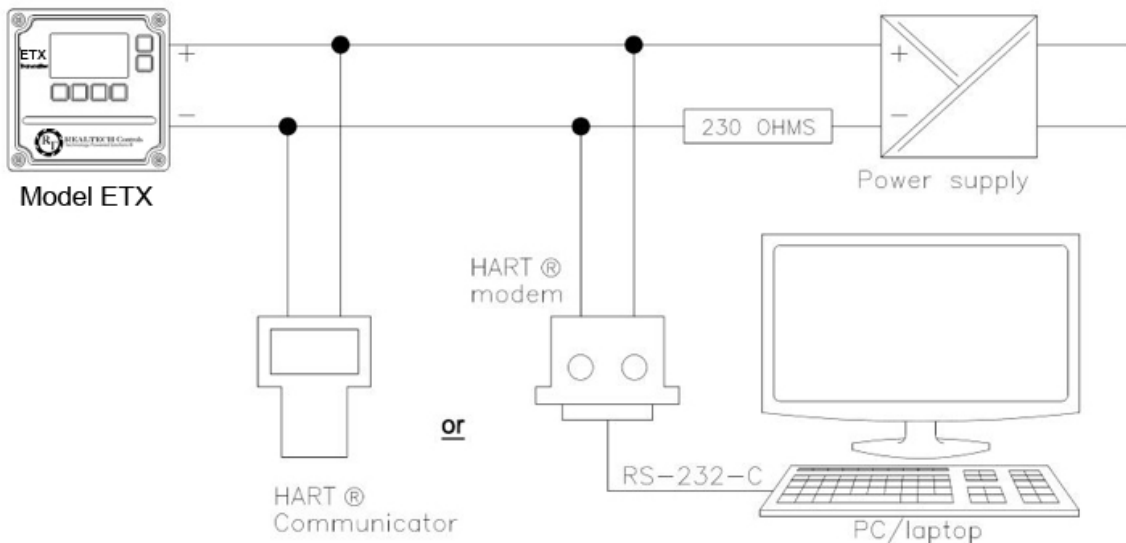

2.2.4 WIRING, CONTACT RELAY OUTPUTS

The standard configuration has three SPDT 230V 5 A Relays that can be wired with **normally open (NO)** or **normally closed (NC)**. The default configuration is set to use the relays as normally open.

2.2.5 WIRING, SERIAL OUTPUT MODBUS RTU

Attach the sensor wires as shown in figure 2.2.2 or as described on the diagram inside the ETX cover. Feed the sensor cable through the gland fitting on the left hand side of the ETX. Do not use the same gland fitting for the AC power or Alarm/Relays. See MODBUS command register in Appendix D.

3.0 OPERATION

The RealTech Controls Model ETX transmitter is an intelligent, single or dual channel multi-parameter transmitter designed for the online continuous measurement of pH, ORP, pION, conductivity, resistivity, Dissolved Oxygen, Turbidity and/or Suspended Solids in a general purpose industrial environment. The Model ETX transmitter digitally communicates with any RealTech Controls S80, TR80, TR82 and DO82 digital sensors. The measurement identity is contained in the sensor's memory. When an RealTech Controls sensor is connected to the transmitter it automatically configures the transmitter's menus and display screens to the measured parameter. For detailed instructions on all the functions of the ETX Transmitter, refer to the ETX instruction manual. This manual contains specific functions of the ETX in use with the TR80 Turbidity/SS Sensor.

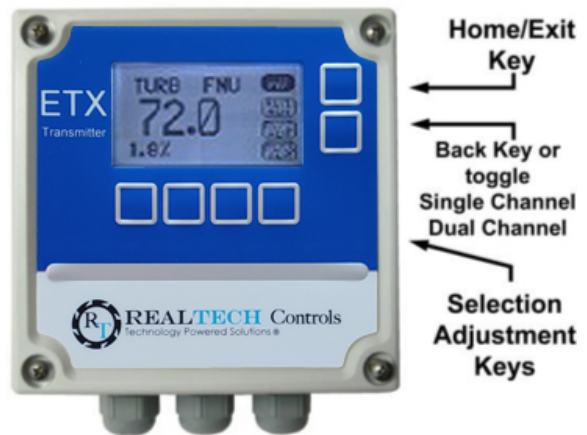

3.1 CONFIGURE AUTOMATED WIPER FUNCTION

The automated wiper function utilizes an internal relay in the ETX to activate the wiper. The period (frequency), duration, and hold functions can be programmed. For the following standard automated wiper function, the wiper is activated every 15 minutes for 15 seconds and the reading of the sensor is held to the value just before the wiper is activated for 15 seconds and then returns to normal active reading. This way the sensor does not change its reading due to "seeing" the wiper. ETX programming for the automated wiper function as follows:

- ❖ Double press any button on front panel
- ❖ Then select the following
- ❖ HOME Menu → Press CONFIG → XMTR → OUTPUT → RELAYS→RLY1→TIMED
- ❖ Then set the configuration to:
 - Period: 15 min
 - Duration: 15 sec
 - HOLD: Duration
- ❖ Exit and save changes

For detailed instructions of the ETX Transmitter, refer to the ETX Instruction manual.

Spare or replacement wipers – order Part No. 1000296-1 Wiper Kit (2 wiper arms and 5 wiper blades)

4.0 CALIBRATION

The TRITON TR80 turbidity sensors can be configured and factory calibrated (ready to use) in four different ranges, and calibration at the installation site can also be accomplished with a 3-point calibration method as describe in the following instructions.

The Model ETX turbidity analyzer was calibrated at the factory before shipment in three Formazine solutions using the values listed below. The calibration was performed with the three solutions specific for the NTU range of the sensor ordered.

Changing the range of the sensor or changing the measurement until will require a new three point calibration. The calibration points for the three point calibration are 0%, 50%, and 100% of the measurement range, NTU, FNU, ppm, mg/L, or % Solids. Calibrations of NTU or FNU can be made with Formazine solutions diluted from the 4000 NTU stock solution to the values listed in the table below. Calibrations of ppm, mg/L, and % Solids require the actual process solutions to the values listed in the table below. The 100% solution for the ppm, mg/L, and % solids should be near the high point of the measurement, it does not need to be the maximum value but it should be in the upper range of the measurement. The value of the solution must be known or determined by another method such as a grab sample and laboratory measurement. Then make the 50% solution form 1 part of the high sample to one part deionized water, its value is half the high value and finally use deionized water for the 0% solution.

Calibrations should be performed in a vessel with similar characteristics to the actual process installation. Black plastic containers work best, minimizing reflectance problems in lower NTU solutions. RealTech Controls Offers a TRITON TR80 Turbidity Calibration Kit that includes a TR80 Calibration Cup, 250 ml, 100 ml, and 50 ml graduated cylinder and a 1 liter volumetric flask. The kit provides the necessary laboratory equipment to make calibration standards from a 4000 NTU Formazine stock solution and an easy to use calibration cup. This kit is ideal for calibration of inline pipe mounted TR80 turbidity sensors. For low NTU applications, the calibration should be completed in the flow cell or flow cell with debubbler that the sensor is installed in.

Sensor Measurement Ranges	Calibration Values	Cal Values - other Ranges
0-40 NTU	0 NTU, 20 NTU, 40 NTU	0, 50%, 100% NTU of Range
0-1000 NTU	0 NTU, 500 NTU, 1000 NTU	0, 50%, 100% NTU of Range
0-4000 NTU	0 NTU, 1000 NTU, 2000 NTU	0, 50%, 100% NTU of Range
0-5000 and greater mg/L Suspended Solids	0 NTU, 2500 mg/L, 2000 NTU	0, 50%, 100% mg/L of Range

Example of an mg/L Calibration: The process solution ranges around 3000 mg/L. A liter sample was taken from the process and tested, it was determined to be 27850 mg/L. Keep one liter of the 2850 mg/L solution for the (100%) solution calibration and mix 500 mls of the 100% solution with 500 mls of deionized water, making the (50%) solution, 1425 mg/L and one liter of deionized water (0%). Start the calibration in the deionized water in the calibration cup and accept 0.00 mg/L when prompted, then put the sensor into the 1425 mg/L solution and enter 1425 mg/L when prompted and finally into the 2850 mg/L solution and enter 2850 mg/L. Accept the calibration and put the sensor back into the process.

4.1 AUTO CAL

The TRITON TR80 turbidity sensors use a three point AUTO Cal sequence. Cal 1 is a zero point calibration, Cal 2 is a 50% of the measured range calibration and Cal 3 is a 100% of range calibration.

Action	Prompt
Double Press any Button	MENU HOME, Hold is OFF
Press HOLD	Hold freezes 4-20 mA Output and locks Alarm Relays during Calibration
Press CAL	Is this is a new Sensor? (Yes erases CAL Log in INFO, NO adds CAL to existing Log)
Press YES/NO	Place Sensor in 0.00 NTU (or FNU, mg/L, ppm, % Solids) CAL Solution
AUTO (Cal-1)	STABILIZING, xx.xx NTU x.xx V, 0.00 NTU corrected, Accept Cal 1?
Press YES	Place sensor in 100% solution
	STABILIZING, 1000 NTU 2.46V, 1000.0 ppm corrected, Accept Cal 3?
Press YES/NO	If suggested corrected value is not correct press NO, Enter CAL 3 Value
Press ▲▼ NEXT	xxxx.x NTU (use arrows and NEXT keys to enter Cal value)
Press OK	xxxx.x NTU, xxx.x V, 500.0 NTU corrected Accept Cal 2?
Press YES	Place sensor on 100% solution
	STABILIZING, 1000 NTU 2.46V, 1000.0 ppm corrected, Accept Cal 3?
Press YES/NO	If suggested corrected value is not correct press NO, enter CAL 3 Value
Press ▲▼ NEXT	xxxx.x NTU (use arrows and NEXT keys to enter Cal value)
Press OK	1000 NTU, 2.46 V, 1000.0 NTU corrected Accept Cal 3?
Press OK	Calibration complete, returns to Cal Menu
Press HOME	Hold is ON
Press HOLD	Turn off Hold
Press EXIT	Main Display

4.2 STANDARDIZE

Standardize is an online/in process Zero Point Calibration Only. To change a non-zero value to a new value use the Slope feature in the Manual Cal section (see below). Standardize is used to zero out the reflectance effects generated by the installation. The sensor will generate an mV signal in a zero NTU environment and this will be different than the zero point value recorded in the AUTO Cal. Standardize shifts the calibration curve to the new zero value. Perform a Standardize calibration with the sensor installed in the process line or tank and immersed in clear water only.

Action	Prompt
Double Press any Button	MENU HOME, Hold is OFF
Press HOLD	Hold freezes 4-20 mA Output and locks Alarm Relays during Calibration
Press CAL	Place Sensor in Air or with the sensor in the process solution
Press STAND	Enter Zero Value
Press ▲▼ NEXT	0.00 NTU or ppm, mg/L, % Solids (use arrows and NEXT to enter process value)
Press OK	0.00 NTU, Accept Value?
Press YES	Stand Cal Complete: 8.61 NTU, DESIRED VALUE: 0.00 NTU, OFFSET 8.61 NTU
Press OK	Back to Cal Menu
Press HOME	Hold is ON (Press HOLD to turn off Hold)
Press HOLD	Turn off Hold
Press EXIT	Main Display

4.3 MANUAL CAL

Manual Cal provides two options, OFFSET and SLOPE. **OFFSET** is an online/in process **Zero Point Calibration Only**. It is the same value that is adjusted in **Standardize** and it is set the same way. **SLOPE** is an adjustment of the NTU/volt aspect of the turbidity curve pivoting from the Offset point. The SLOPE window displays a unit less number that is changed to adjust calibration.

Example: TRITON® TR80 in 400 NTU solution but reads 380 NTU. The SLOPE reads 108. The slope of the calibration curve needs to increase so that the voltage so that the voltage that is generating 380 NTU will generate 400 NTU. To determine the new slope, first divide the desired value (400 NTU) by the actual value (380 NTU) and multiply the current slope by that number. $400 \text{ NTU} / 380 \text{ NTU} * 108 = 113.7$ the new slope. Enter 113.7 in the SLOPE window, save the Calibration, and the analyzer will read 400 NTU.

SLOPE ADJUSTMENT

Action	Prompt
Double Press any Button	MENU HOME, Hold is OFF
Press HOLD	Hold freezes 4-20 mA Output and locks Alarm Relays during Calibration
Press CAL	Place Sensor in Air or with the sensor in the process solution
Press MANUAL	OFFSET or SLOPE
Press SLOPE	Enter SLOPE Value 108.00
Press ▲▼ NEXT	113.7 (use arrows and NEXT to enter process value)
Press OK	113.7 Accept Value?
Press YES	Manual Cal Complete: OFFSET 8.61 NTU, SLOPE 113.7
Press OK	Back to Cal Menu
Press HOME	Hold is ON (Press HOLD to turn off Hold)
Press HOLD	Turn off Hold
Press EXIT	Main Display

5.0 MAINTENANCE

The TR80 turbidity sensors don't require periodic service except in coating applications. Quarterly checks should be performed to assure the accuracy of the measurement.

The TR80 response can become sluggish due to coating from materials in the process solution. Periodic cleaning will minimize drift and maintain the sensors response.

CLEANING

The most important maintenance item is keeping the optically clear epoxy window clean. The TR80 wiper will clean the surface of the sensor and also the sensors are fairly robust and can be cleaned with alcohols, detergents or very diluted acids to remove coatings caused by greases, oils or films. **Do not use solvents such as MEK, Toluene, Acetone, or trichloroethylene on TR80 sensors.** A soft tooth brush or paper towel should be used to remove soft coatings.

WIPER REPLACEMENT

The frequency of wiper replacement depends on the application. The wiper and/or wiper assembly arm can be replaced in the field. To replace the wiper, order P/N 1000296-1 Wiper Kit – TR80. The kit contains a 0.050" hex driver needed to remove the wiper set screw.

6.0 SPECIFICATIONS

6.1 TR80 TURBIDITY/SUSPENDED SOLIDS SENSOR

Measuring principle:

Particle caused back scattering of near infrared light

90° scattered light method in accordance with ISO 7011/EN27087

Measuring Range:

-1 Sensor

0.0 ... 1000 mg/L & 0 ... 1000 NTU, FNU

-3 Sensor

0 ... 5000 or greater mg/L or 0 ... 4000 NTU, FNU, ppm, mg/L and %solids

-4 Sensor

0 ... 40 mg/L or 0 ... 4000 NTU, FNU

Process Temperature Range:

-5 ... 50°C

Temperature Compensation:

Internal Temperature compensation

Process pressure range:

50 psi maximum in Flow Cell

Wetted Materials

Sensor body: CPVC, Polypro optional

Sensing end: epoxy

Process Connection:

3/4" NPT Treads – back of sensor

Can be inserted in 1 ¼" MPNPT Gland Fitting or 1 inch pipe fitting/couplings

Electrical Connection:

Water Proof 6-wire measuring cable (Standard)

Cable Length:

10ft. (3.0 m), 20ft (6.1 m), 30ft (9.1 m) cables

6.2 ETX TRANSMITTER SPECIFICATIONS

Input specification:	Digital protocol, all RealTech Controls S80 sensors Optional analog to digital converter, 5 inputs [mV+, mV-, solution ground, temp + temp – (100 K-ohm)]
Input Ranges:	0 – 4000 NTU/FNU, 0 – 9999 ppm, mg/l, 0 – 100% % solids
Accuracy:	2% of reading
Output Signals:	Non-isolated 4-20 mA output (standard, one per Channel), Fault Condition: 3.5 mA, 22 mA or none Modbus RTU (standard) HART® (optional)
Contact Relays:	(optional) Three (3) SPDT, 1 form C, 250 VAC, 10 Amp resistive maximum, relays, user configurable as Hi/Lo alarms with expiration timer, Periodic Timers or Fault alarms
Display:	128 x 64 pixels (2.75" x 1.5") LCD, Black on Grey background on loop powered instruments, Blue on White background with LED backlight on 100-250 VAC and 24 VDC powered instruments, English or icon based menus, numeric and graphical displays
Enclosure:	Beige Polycarbonate, IP65, weatherproof, ½ DIN, (L x W x D) 5.7: X 5.7" X 3.5" (14.4cm X 14.4cm x 9.0cm)
Power:	Code -0 Loop powered, 24 VDC 600 Ω maximum load (18-36VDC @ 0.3W Maximum) Code -1 24 VDC (18-36 VDC @ 4W Maximum) Code -2 100-240 VAC, 50/60 Hz, 4W, protected with 250V, 1A, Slow Blow fuse

Environmental Conditions

Outdoor use (IP65)

Ambient Temperature:	-20°C - 70°C (24 VDC Models) -20°C - 60°C (100-240 VAC Models)
-----------------------------	---

Storage Temperature: -30°C - 85°C

Relatively Humidity: 0 – 80%, up to 31°C
Decreasing linearly to 50% RH a 40°C

Altitude: Up to 2000 m (6500 ft)

Mains Supply Voltage: Fluctuations up to ±10% of the nominal voltage
Transient over voltages: CAT II
Pollution Degree: 2

Model Triton®TR80 Turbidity Sensor, Part # Guide						
TR80	Sensor Style (optical configuration)					
	1	Flat Surface optics				
		Process Connection				
		0	None			
		1	1" MNPT Nylon Gland Fitting			
		2	Flow Through Cell, 2 x 2" FNPT entries, 1 x 1" FNPT sensor port			
		5	Flow Through Cell, 2 x 2" FNPT entries, 1 x 1" FNPT sensor port with spray cleaner			
		8	De-Bubbler ¾" FNPT entries			
			Cable Length			
			01	10 ft (3.0 m)		
			02	20 ft (6.1 m)		
			03	30 ft (9.1 m)		
				Measurement Ranges		
				0	0-1000 NTU	
				2	0-4000 NTU	
		4		< 40 NTU (Calibration in Flow Cell/DB)		
TR80-	1	0	01	2		

7.0 TROUBLESHOOTING

Symptom	Probable Cause	Remedy
Blank Display	No Power Sensor Failure, causing power draw down below transmitter threshold	Check power source, 24 VDC loop, 24VDC, 110/220VAC Unplug sensor from transmitter, replace sensor if instrument powers up.
Incorrect Readings	Sensor needs calibration Incorrect Temperature measurement Temperature Compensation set up incorrectly	Perform a standardization calibration. See INFO for calibration log Calibrate/Trim Temperature to correct value Verify: 0.33% for pH, pION 0.00% for ORP 4.0% for DO
"Looking For Sensor" prompt	Lost connection between sensor and transmitter	Check sensor connection to transmitter: loose connector? Visually inspect cable for cuts or crushed areas, replace sensor if cable is compromised

8.0 PARTS AND ACCESSORIES (ETX)

8.1 FRONT PANEL CONTROL BOARD EXPLODED

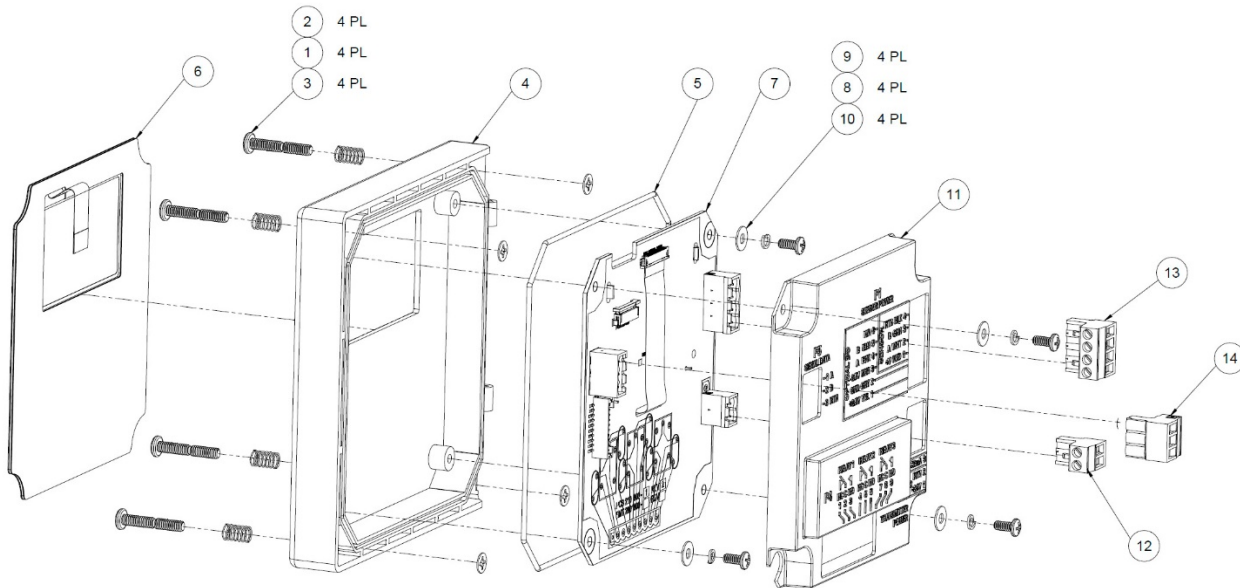

8.2 FRONT PANEL CONTROL BOARD EXPLODED, WITH RELAYS

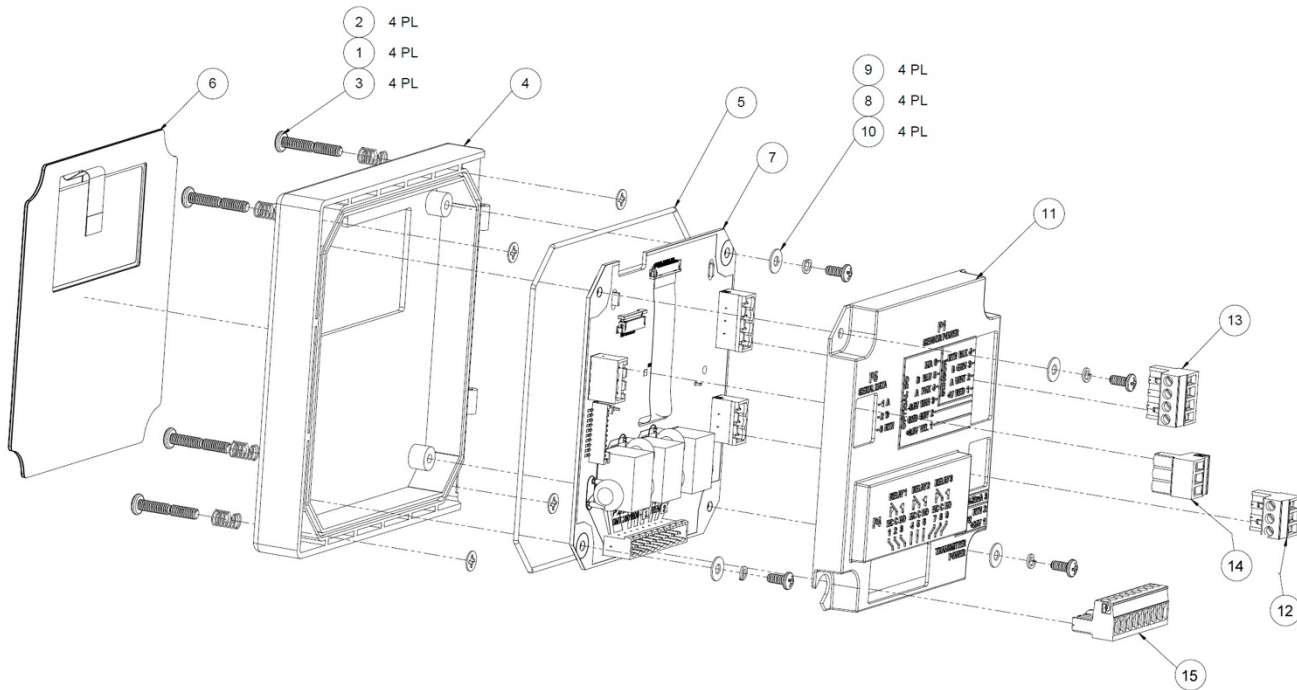

Item #	Part #	Description
1	9630005	Spring, Mounting Screw Set
2	9870621	Retaining Washer, Mounting Screw Set
3	3600390	8-32 x 1" SS Screw, Mounting Screw Set
4	3400152	Front Housing
5	9560005	Sealing O-ring, grey silicone
6	9240503-1	Touch pad membrane
7	2101800-1	PCB, Control Board, Loop Powered
7	2101800-2	PCB, Control Board, Loop Powered, Relays
7	2101800-3	PCB, Control Board, Loop Powered, HART
8	9870650	Locking Washer, PCB Screw Set
9	9730905	6-32 x 5/16" SS Screw, PCB Screw Set
10	9870620	Flat Washer, PCB Screw Set
11	3400006-1	Control Board Cover
12	9090112	24 VDC, 4-20 mA Terminal Black/2 pins
13	9090114	Sensor Terminal Block/4pins
14	9090113	Serial Connection Terminal Block/3 pins
15	9090119	Serial Connection Terminal Block/9 pins

8.3 TRANSMITTER CASE, BACK WITH CABLE GLANDS

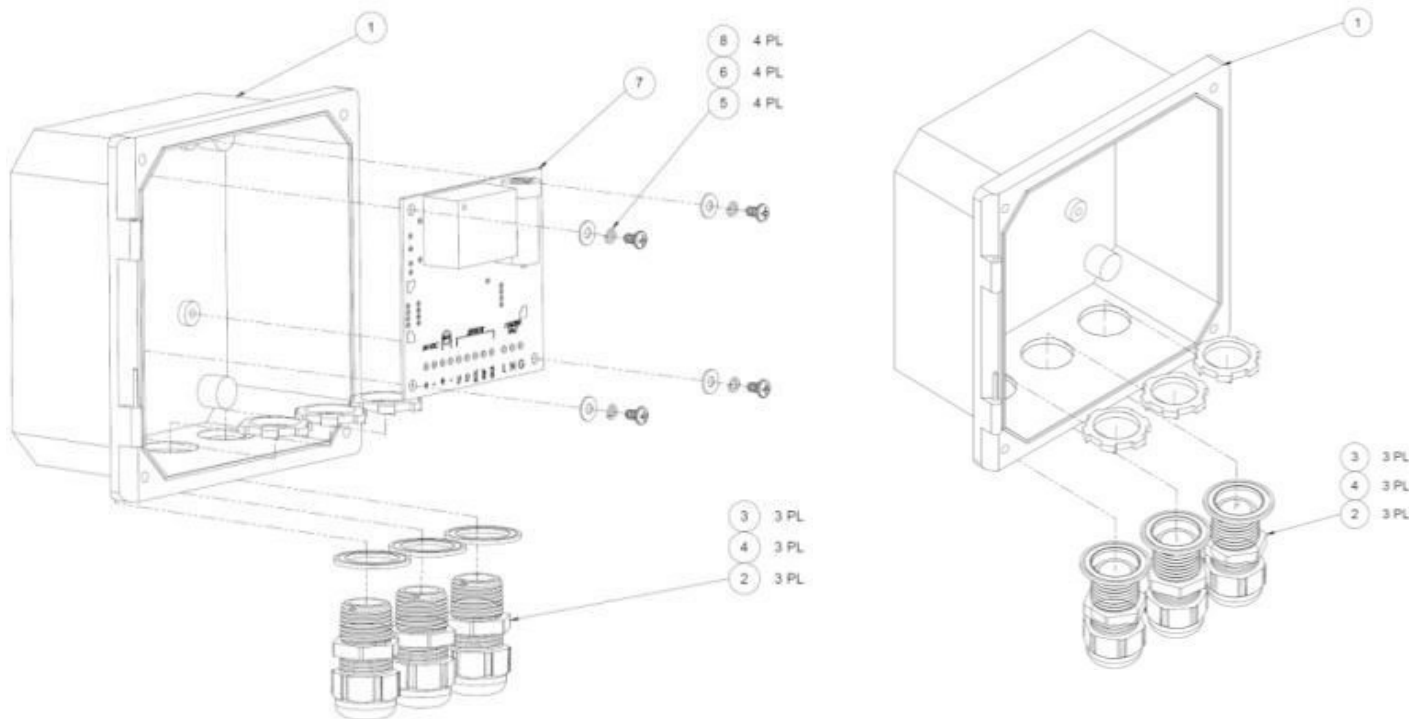

Item #	Part #	Description
1	3600449	Transmitter Case
2	9360005	PVC Cable Gland, 1/2" NPT, Grey
3	9300034	Locking Nut, 1/2" NPT, Steel
4	9300017	Sealing ring, 1/2" elastomer
5	9870650	Split Washer, PS mounting
6	9870620	Flat Washer, PS mounting
7	2101820-1	Power Supply Board
8	9730604	6-32 x 1/4" screw, SS, PS mounting

8.4 REPLACEMENT PARTS

Part #	Description
2000002-1	Front Panel, Loop-Powered
2000002-2	Front Panel, AC/DC Powered
2000002-3	Front Panel, Loop-Powered, Hart Output
2101820-1	Power Supply Board, 110/220 VAC Input
2101820-3	Power Supply Board, 110/220 VAC Input, w/preamp
2101820-4	Preamp Board
3400006	Control Board Cover
9090112	Connector Plug, 2 Position (Loop, AC/DC, or Hart Versions)
9090113	Connector Plug, 3 Position (Loop or AC/DC Versions)
9090114	Connector Plug, 4 Position (Loop, AC/DC or Hart Versions)
9090119	Connector Plug, 9 Position (AC/DC Version)
9240503-1	Front Panel Membrane Switch
9300017	Sealing ring, Cable Gland
9300034	Locking Nut, Cable Gland
9360005	Fitting, Cable Gland
9830214	Screw, Front Panel
1000296-1	TR80 Spare Wiper Kit (2 wiper arms, 5 wipers blades)

8.5 ACCESSORIES

Part #	Description
2000006	Kit, Universal Mount
2000007	Kit, Handrail Mount
2000008	Kit, Panel Mount
1000300-1	4-20 mA USB Data Logger
9130007	Replacement Battery for Data Logger
1000260-1	Sunshield for Pole Mount
1000260-2	Sunshield for Rail Mount



5444 Sepulveda Blvd • Sherman Oaks, CA 91411 • USA • +1-818-606-0562 • realtechcontrols.com